

Zilla SLIMLINE FIXTURE

IMPORTANT SAFETY INSTRUCTIONS

THIS PRODUCT HAS A POLARIZED PLUG (ONE BLADE IS WIDER THAN THE OTHER) AS A FEATURE TO REDUCE THE RISK OF ELECTRIC SHOCK. THIS PLUG WILL FIT IN A POLARIZED OUTLET ONLY ONE WAY. IF THE PLUG DOES NOT FIT FULLY IN THE OUTLET, REVERSE THE PLUG. IF IT STILL DOES NOT FIT, CONTACT A QUALIFIED ELECTRICIAN. NEVER USE WITH AN EXTENSION CORD UNLESS PLUG CAN BE FULLY INSERTED. DO NOT ALTER THE PLUG.

CAUTION: TO PREVENT ELECTRIC SHOCK, MATCH WIDE BLADE OF PLUG TO WIDE SLOT, FULLY INSERT.

ATTENTION: POUR ÉVITER UN CHOC ÉLECTRIQUE, PRÉSENTER LA LAME LARGE À LA FENTE LARGE ET POUSSER JUSQU'AU FOND.

SAVE THESE INSTRUCTIONS

Portable Luminaire
Model: 00726 & 00728
Electrical Rating: 120 V, 0.171 A, 60 Hz



211700

CAUTION: To reduce the risk of fire, electric shock, or injury to persons:

1. Turn off, unplug and allow to cool before replacing lamp.
2. Use only Fluorescent 15 watt T8 lamps (F15T8).
3. Not intended for surface installation inside built-in furnishings such as kitchen cabinets, china cabinets or trophy cases.
4. Household use only.
5. Not intended for wet or damp locations.
6. The National Electrical Code (NEC) does not permit cords to be concealed where damage to insulation may go unnoticed. To prevent fire danger, do not run cord behind walls, ceilings, soffits, or cabinets where it may be inaccessible for examination. Cords should be visually examined periodically and immediately replaced when damage is noted.

INSTALLATION Model Number 00726 & 00728

1. Make sure all components are supplied and the "Important Safety Instructions" have been reviewed prior to plugging in and powering the luminaire. The Slimline fixture comes fully assembled. No additional assembly required.

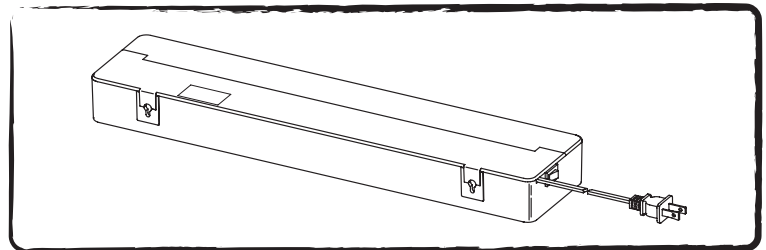

BULB REPLACEMENT

1. Power off and unplug luminaire.
2. Remove two recessed screws on opposite sides of luminaire.
3. Remove lens.
4. Remove used bulb.
5. Install new bulb.
6. Replace lens, install screws.
7. Plug in luminaire, power on.

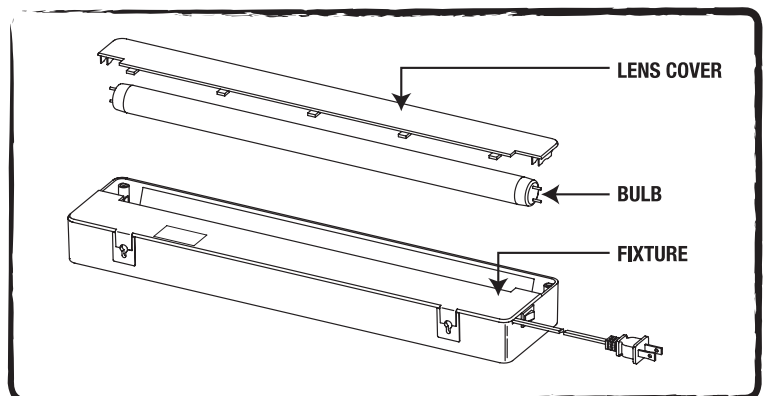

Zilla SLIMLINE FIXTURE

12 MONTH LIMITED WARRANTY

WHAT THE WARRANTY COVERS:

Zilla (Company) warrants this product (see Exclusions below) to the original purchaser against defective material and workmanship that occurs during normal use for 12 months from the date of original purchase. Company will, at Company's option, either repair or replace same without charge (no cash refunds will be made).

EXCLUSIONS:

1. Damage resulting from accident, misuse, abuse, lack of reasonable care, subjecting the product to any but the specified electrical service, other than normal and ordinary use of the product, subjecting the product to abnormal working conditions or any other failure not resulting from defects in materials or workmanship.
2. Damage resulting from modification, tampering with or attempted repair by anyone other than the Company.
3. Transfer of product to someone other than the original consumer purchaser.

LIMITATION OF IMPLIED WARRANTIES AND EXCLUSION OF CERTAIN DAMAGES:

THE COMPANY DISCLAIMS LIABILITY FOR INCIDENTAL AND CONSEQUENTIAL DAMAGES FOR BREACH OF ANY EXPRESS OR IMPLIED WARRANTY, INCLUDING ANY IMPLIED WARRANTY OF MERCHANTABILITY, WITH RESPECT TO THIS PRODUCT. THIS WRITING CONSTITUTES THE ENTIRE AGREEMENT OF THE PARTIES WITH RESPECT TO THE SUBJECT MATTER HEREOF; NO WAIVER OR AMENDMENT SHALL BE VALID UNLESS IN WRITING SIGNED BY THE COMPANY. Some states do not allow the exclusion or limitation of consequential damages, so the above limitation or exclusion may not apply to you.

FOR WARRANTY/REPAIRS/RETURNS:

Product must be accompanied by letter of explanation and original purchase receipt. You must pay any postage, shipping charges, insurance costs and other expenses to return the product to Zilla. However, if the necessary repairs are covered by the warranty, Company will pay the return shipping charges to any destination within the United States or Canada.

Contact the Company by telephone: 888-255-4527
or e-mail: warranty@zilla-rules.com or
contact the Company by writing to:

Zilla
5401 West Oakwood Park Drive
Franklin, WI 53132

 **LAMP CONTAINS MERCURY**
Manage in Accord with Disposal Laws.
See: www.lamprecycle.org

REPTILE REWARDS PROGRAM

*Reptiles
shouldn't
have all
the fun.*



 **REWARD YOURSELF!**

When you buy Zilla® brand products, you're buying the best for your demanding little critter. Such a show of commitment deserves a reward. Use your z-points found on your Zilla® packaging, to go shopping for all sorts of new items. You deserve it.

WHAT ARE Z-POINTS AND HOW DO I GET THEM?

Every time you purchase a Zilla® product, whether it's a reptile kit, some bedding, food, lighting or decor, you'll get some Z-Points. It's our way of saying thanks for purchasing the coolest reptile products on the planet. And they add up quick.



WHAT CAN I GET WITH MY Z-POINTS?

Besides envy among your friends, you can get some sweet Zilla® merchandise – like awesome baseball caps, limited edition posters, sports bottles, mugs, jackets and T-shirts. The kind that make people say, "Dude, where'd you get that gear?"

WHO GETS TO PICK THE ITEMS, ME OR MY REPTILE?

You do. This is your reward for taking such good care of your pet. Which isn't to say you can't let your reptile borrow your bandana or wear your hat for awhile.

HOW DO I REDEEM MY Z-POINTS?

It's easy. Just go to: zilla-rules.com/rewards page to view and choose the gear you want. Once you've collected the Z-Points you need, simply fill out the form and mail the correct amount of Z-Point coupons along with the reward request form to the address listed.

For more details visit zilla-rules.com/rewards